



miglas

H I G H P E R F O R M A N C E W I N D O W S

Innovation Beyond Double Glazing

MIGLAS

Miglas provide high quality Australian-made and designed double glazed windows and doors that combine the advantages of both timber and aluminium windows to create a low maintenance, energy-efficient and thermally stable suite. This unique system provides comfort and protection against the harsh Australian climate all year round, while allowing you full architectural freedom with a wide range of styles, sizes and colours.

“Our experienced team will work with you to ensure you select the best design option for your project.”

- Anatol Miglas







Made in Australia

The Miglas AliClad window is purpose designed for Australian conditions, and manufactured right here in Melbourne by a third generation family business. Ultra Precision CNC machinery is utilised for efficient and accurate production with all major components (timber, glass & aluminium) sourced locally from Australian suppliers.



Innovation Delivers Unique Design

With years of experience supplying double glazed windows and doors to Australia's alpine regions, Miglas has a deep understanding of both energy and climate issues.

Analysis shows that sustainable energy efficiency goes above and beyond simply double glazing. Research into the failings of both timber and aluminium windows showed that remarkably, where each of these proven materials had its weakness, the other had its strength.

When combined they provided the ultimate window design for Australian conditions; Miglas AliClad.

During the extensive product development of this new window system, many innovative features were the result of the unique Miglas difference.

Taking into consideration the beauty and warmth of timber, combining it with the durability of aluminium, and finishing with the efficiency of double glazing. You end up with the perfect window.

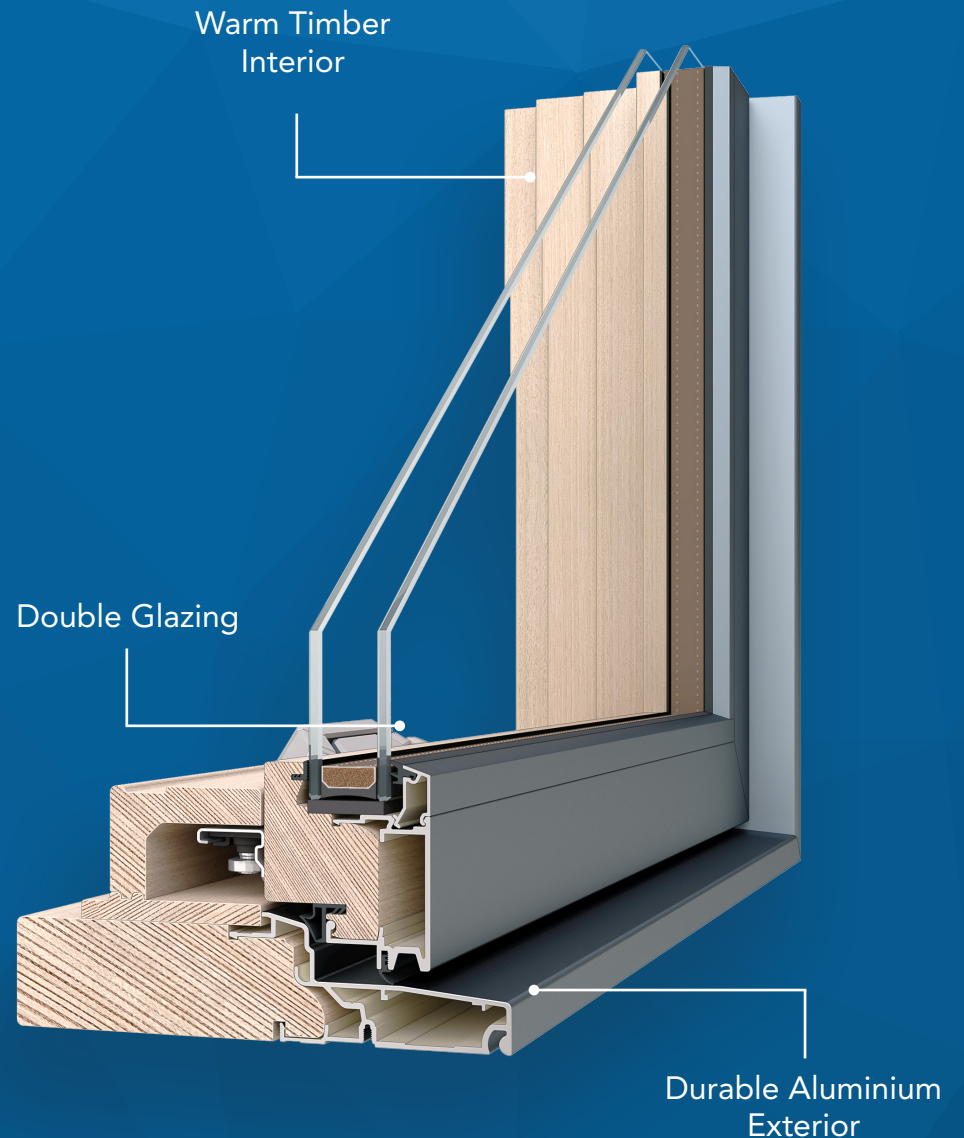

ELEGANT WARM INTERIOR

TIMBER FOR STRENGTH & BEAUTY

- Natural thermal insulation
- Sustainable Australian hardwood
- Suitable for all internal finishes

PREMIUM HARDWARE RANGE

- Secure multipoint locking
- Large sash capability for wide openings
- Fully concealed sash operator
- Stainless concealed automation

INTERIOR DECOR

- Independent from exterior colours
- Colour/finish to suit each room in your home
- Difficult to paint areas eliminated

BUILT IN INSECT SCREEN

- Easy to remove
- Seamless finish leaves no gaps
- All screen material options
- Choice of colours



MODERN STYLISH EXTERIOR

ALUMINIUM FOR DURABILITY & STABILITY

- Contemporary architectural extrusions
- Freedom of colour choice to suit exterior finishes
- Low maintenance finish
- Full facade capability

HIGH PERFORMANCE DOUBLE GLAZING

- High energy efficiency ratings
- Glazing options to match your needs

RESISTING THE ELEMENTS

- Low maintenance
- Best performance ratings
- Suitable for all Australian conditions

SUPERIOR SEALING

- Concealed double sash seals
- Latest Silicone/TPE technology

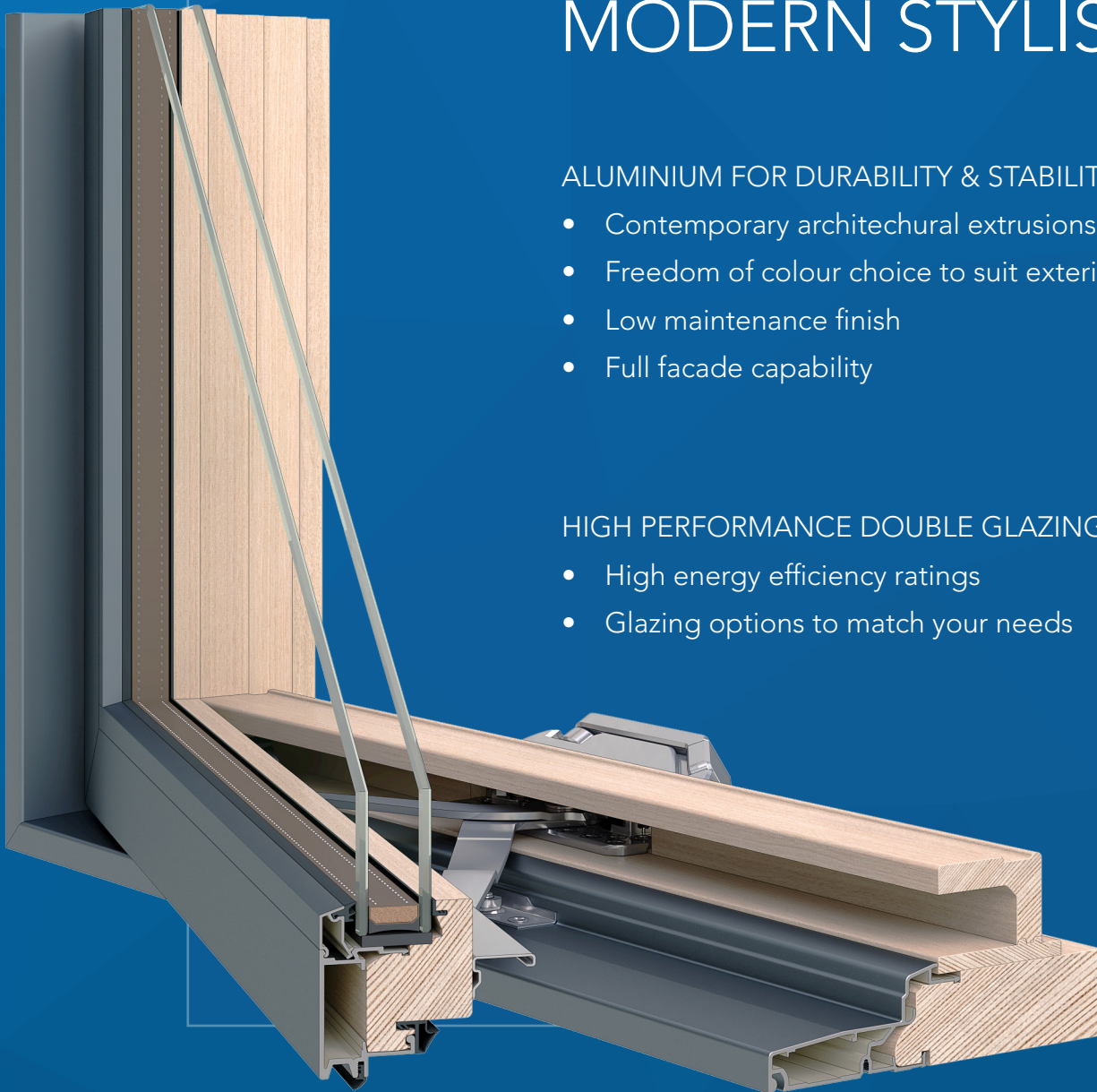



YOUR HOME DESERVES THE BEST

Discover how Miglas can work with you to accomplish your vision

When you picture how your new home will look and you visualise how your home reflects your lifestyle and values, the windows and doors will play a major part in shaping that dream into a reality. Here at Miglas, we share your vision for perfection.

“Your home deserves the best” is part of the Miglas culture. Through innovation and a commitment to Australian materials, AliClad windows and doors deliver far more than just double glazing, allowing you to reap the benefits.

The innovative design will meet even the harshest efficiency and sizing requirements.

Miglas AliClad is an enduring design concept as all parameters will stand the test of time far beyond competitors products.

The “Miglas difference” is not only in the composition of the window and door profiles but carries through to the modular construction, providing greater freedom in how you design and combine your windows and doors.

Miglas provide a customised solution from a complete range of thermally efficient performance products.

Miglas AliClad composite windows and doors add value to your home while ensuring your comfort and security.

Owing to our design and high performance components, Miglas windows and doors can be manufactured to meet the most exacting demands for thermal efficiency, solar heat gain, and air infiltration as well as eco aspects and bushfire ratings.

SUSTAINABLE AUSTRALIAN DESIGN

Australian Owned, Engineered & Manufactured

Calculating the life cycle saving of the product shows an investment that pays off. A 2007 Study commissioned by the Australian Government found aluminium skinned timber windows (composite products) had the longest product life cycle, twice that of a uPVC window and the lowest embodied Co² (40% lower than that of a timber only window) during a life cycle assessment.

The thermal efficiency reduces the impact of heating and cooling emissions into our environment, where every component contributes with its specific advantage.

Aluminium

Used as an external cladding only, the amount of aluminium is reduced significantly compared to an all aluminium window, while still maintaining the advantage of durability and low maintenance and a lower embodied energy.

Durability means each window remains longer in the building and the replacement cycle is vastly reduced, therefore less energy for replacement in the long term. An exterior that never needs painting ensures no harmful and toxic paints are used during its life in a building, resulting in less water usage and no toxic wash off.

Timber

The Victorian Ash timber used for Miglas windows and doors is harvested from sustainably managed resources. The forests are AFS (Australian Forestry Standard) certified which is recognised by the European forestry standard PEFC. Sourcing from regional forests minimises the impact of transport and keeps total emissions to a minimum. The combined result of the components is a durable, sustainable product, particularly in comparison with other available window options such as aluminium-only or uPVC.

Energy-efficient, durable & sustainable design for a cleaner environment.

Miglas' windows meet the Australian Standards regulations AS2047 and AS1288. These standards regulate the wind pressure, water infiltration & glazing ratings of the window. Other benefits can include bushfire resistance, acoustic minimisation and security performance.

Every region has different specific requirements and these aspects have to be clarified prior to quote and manufacturing. According to AS2047 this has to be nominated by the applicant or the approving authority.

AGWA - Australian Glass & Window Association



Miglas is a long serving member of AGWA. It is our ambition to actively participate in the development of standards, ratings and certificates.

Having our staff attend seminars offered by various industry related organisations, enables us to meet your requirements with up to date knowledge.

Under the Building Code of Australia (BCA) windows and doors have to meet minimum mandatory specifications of AS2047. Miglas exceeds all these standards, with the following tests included:

Deflection - Wind Pressure Test (Structural Performance)

Measures the amount of air pressure (wind load) a window can resist before failing. The amount of structural pressure ratings required for windows in your area is often determined by local code requirements. Miglas window systems have been tested to wind load ratings of N6. This means the higher the structural performance ratings, the more wind load a window can resist.

Water Penetration Resistance

Water infiltration measures the amount of water and pressure that a window can resist keeping the water from leaking through it. The higher the water infiltration rating, the better the window is at resisting water leakage with Miglas windows exceeding industry standards reaching between N4-N6.

DOUBLE GLAZING

Superior thermal performance is standard across the Miglas range

How does double glazing work?

Double glazing, or an Insulated Glazing Unit (IGU), consists of two sheets of glass separated by a pocket of air, or inert gas (argon) to provide an insulative thermal barrier. The pocket is designed to be around 14mm which is optimal to ensure there is no movement in the air to cause thermal convection.

If you imagine putting hot coffee in a thermos flask versus a plastic container, which product will retain its temperature for longer? This concept is the same for double glazing versus single glazing.

The increased thermal insulation of the double glazed unit provides many benefits to the home, including minimising ambient heat gain in summer and minimising heat loss in winter. This provides a more consistent temperature and reduces the requirements for heating/cooling the home.

The interior surface temperature of the glass is also closer to that of the inside of the home in an IGU and this greatly increases the condensation resistance of the glass.

Depending on what you want to achieve, different glass mix solutions can be utilised to achieve the following:

- Heat Gain / Loss Reduction
- Noise Control
- Bushfire Safety
- Low U-Values
- Security & Safety
- Shading/Solar Control

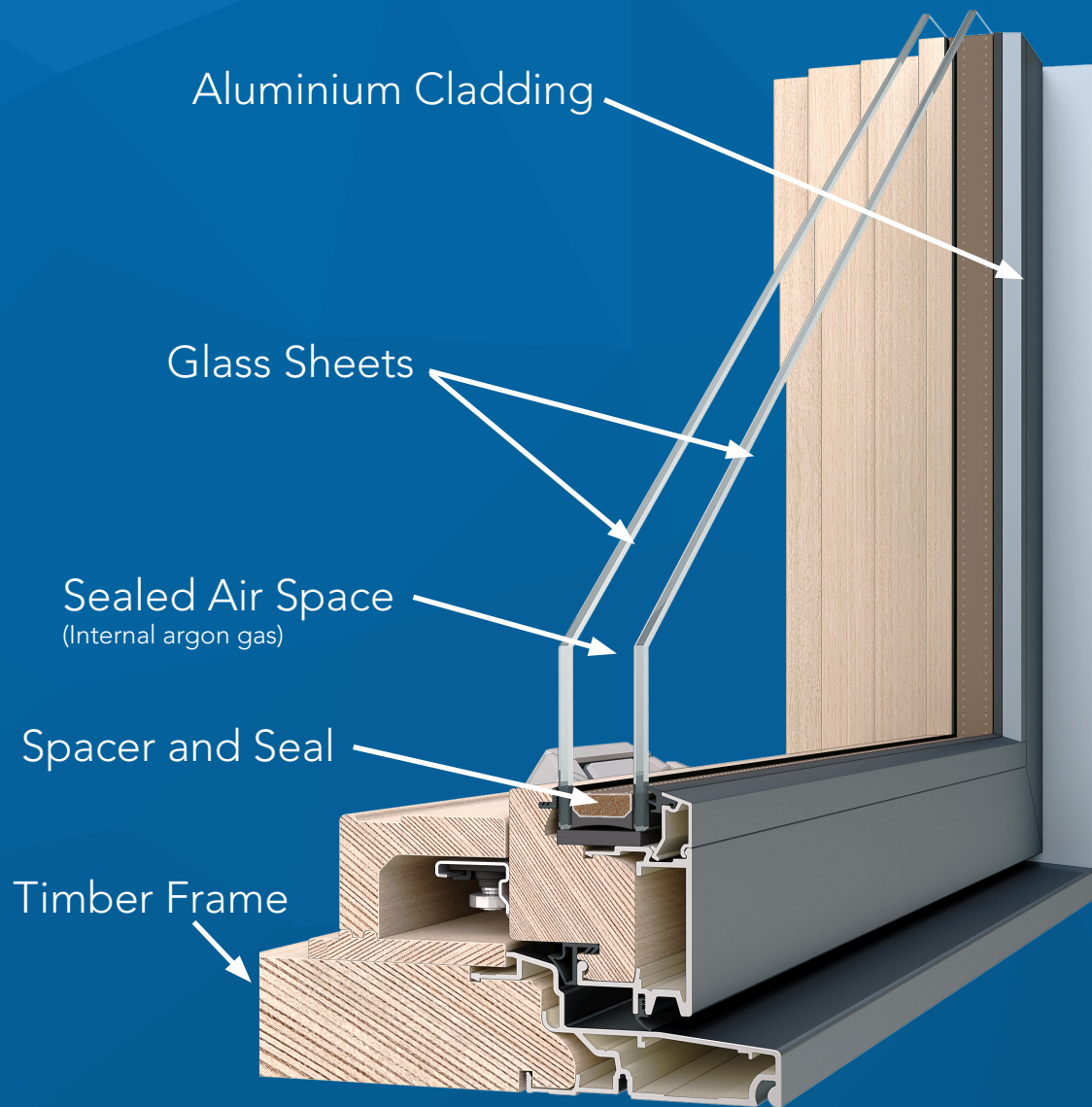

GLAZING OPTIONS

Coatings

Several coating options are available which can provide extra insulation and reduce UV. These coatings will assist in keeping your home warm in winter and cool in summer.

Acoustics

Special noise reduction laminated glass can be optioned to create a barrier against unwanted noise. (Additionally, this will reduce UV by 99%)

Security

Special laminated security products that look like standard glass but provide a barrier to forced entry that is 20 times harder to break through than standard float glass.

Bushfire

The Miglas AliClad suite is fully tested and certified compliant to BAL 40. Toughed glazing is required to meet the stringent requirements of BAL ratings and protect against extreme fire conditions.

Leadlight

Leadlights can be produced as an overlay (facsimile) or a traditional leadlight encapsulated within a double glazed unit.

DOUBLE GLAZING OPTIONS

Miglas offers additional options for your double glazing

Soft coat Low E glass is manufactured by applying multiple thin layers of silver and metal oxides to the glass surface by a sputtering deposition process. Sputtered coatings create a finished glass product that is far superior and dynamic in performance, exhibiting very high levels of clarity and without the haze levels associated with the older style Low E coatings.

High performing soft coatings provide an improved balance between Solar Heat Gain Coefficient (SHGC) and U Value when compared to clear and traditional hard coated products, whilst also retaining far superior levels of Visible Light Transmission (VLT).

Due to the 'soft' nature of sputter Low E coatings, the product requires special handling and glass processing techniques and can only be glazed as part of an IGU. The coating faces the airspace on either surface 2 or 3, this protects the coating from environmental conditions and also maximises the overall performance of the IGU.

OptEma™ and Lightbridge™ by Virdian Glass are examples of high performing IGU's manufactured with a sputter Low E coated glass that are available.

OptEma Plus™ (High Solar Heat Gain)

[Centre of Glass U-value 1.37 / SHGC 0.60]

OptEma Plus™ is an ideal IGU solution for cooler climates and southern elevations for both residential new build and renovation projects. Playing a key role in managing both the heat flowing in and the heat flowing out of the glazed elements of the building, OptEma™ helps to make your home cooler in summer and warmer in winter whilst allowing the room to bathe in very high levels of natural light.

In the Miglas AliClad window, OptEma Plus double glazing provides a U Value of 1.7 and a SHGC of 0.55.

Solarban 60® (Low Solar Heat Gain)

[Centre of Glass U-value 1.38 / SHGC 0.39]

The advanced Low-E coating of Solarban® 60 glass transmits more than 70% of the sun's available light into a home while blocking 79% of the sun's damaging UV energy and other contributors to fading—in all, 24% better than standard clear insulating glass. This helps to protect interior furnishings, fabrics and carpets from fading. More importantly, Solarban® 60 glass helps homeowners shield their homes, and their utility bills, from the summer heat and winter chill. Measured against windows assembled with ordinary clear glass, Solarban® 60 glass lessens solar heat gain by more than half. When the seasons turn cold, the high insulating value of Solarban® 60 helps reduce furnace heat loss through windows by up to 50%.

Those qualities have made Solarban® 60 glass the name to know in the window industry for year-round comfort and energy performance.

In the Miglas AliClad Fixed Window, SolarBan 60 glazing provides a U-Value of 1.8 and a SHGC of 0.43

ACOUSTIC OPTIONS

Alongside significantly improved thermal performance, double glazed windows provide substantial acoustic benefits to minimise sound intrusion into your home. While windows are not the only design element to consider in overall acoustic performance, they are likely to be the single biggest area of improvement, with an enormous difference between a poorly designed basic window and a high-end product like the Miglas composite suite.

BUSHFIRE GLAZING OPTIONS

The Miglas AliClad suite is fully tested and certified compliant to BAL 40. Toughed glazing is required to meet the stringent requirements of BAL ratings and protect against extreme fire conditions.

SECURITY OPTIONS

Would you like that extra level of protection for the weak spots of your building without detracting from the design visually? Then special laminated security products, such as IntruderGuard™ are the ideal solution. IntruderGuard™ looks like normal glass but provides a barrier to forced entry that is 20 times harder to break through than standard float glass. So you can stay safe while still having the look that you love.

IntruderGuard™ also reduces the rate at which your furniture fades by absorbing 99% of UV radiation.

LEADLIGHTING

Leadlights can be produced as an overlay (facsimile) or traditional leadlight encapsulated within a double glazed unit. Miglas work with a specialist company to provide a double glass unit to the required specifications to be glazed into our frame. The design and shape options are limitless and provide a heritage look or a classic twist on a modern design.

WINDOWS

Windows are an investment that can remain in a building for more than 50 years. You should value the product regarding its life cycle costs, durability, maintenance, design, and performance.

AWNINGS

CASEMENT

FIXED PICTURE (PANORAMA)

AWNINGS

Awning windows are hinged at the top and open out from the bottom using our smooth action manual scissor window winders or electric actuators.

Folding window winder handles are standard and provide a clean line for curtains and blinds.

An awning is designed to circulate air while protecting the room from light rain. The multipoint sash locks provide security and a positive closure on the seals, meaning unwanted air leakage is reduced to a minimum.

Flyscreens are included as standard in all opening windows and automation options are available for difficult to reach awning applications, providing control at the touch of a button.



Hardware

- Multipoint sash locks
- Bespoke silicone seals
- Stainless steel concealed hinges
- Smooth action scissor winders

Performance

- Up to N6 AS2047 rating
- U-Value as low as 1.9
- Low air infiltration (0.07)
- BAL40 tested & certified

Dimensions

Maximum height: 1800mm

Maximum width: 1800mm

Sizes dependent on glass options
and sash weights

CASEMENT WINDOWS

Casement windows are ideal for ventilation with the casement sash opening on a 90 degree radius.

Quality Interlock stainless steel hardware provides easy opening action and multipoint sash locks ensure security and advanced sealing pressure on the compression gaskets for minimum air leakage.

Folding window winder handles allow a clean line for curtains and blinds and the quality construction, window hardware and seals also provide excellent air and water sealing.

Flyscreens are included as standard in all opening windows and automation options are also available for difficult to reach casement applications, providing control at the touch of a button.



Hardware

- Multipoint sash locks
- Bespoke silicone seals
- Stainless steel concealed hinges
- Smooth dual arm winders

Performance

- Up to N6 AS2047 rating
- U-Value as low as 1.9
- Low air infiltration (0.07)
- BAL40 tested & certified

Dimensions

Maximum height: 2400mm

Maximum width: 900mm

Sizes dependent on glass options
and sash weights

FIXED PICTURE (PANORAMA)

The fixed picture (panorama) windows are ideal to create uninterrupted views and capture the natural light. Quality glazing units and frame constructions are used on Miglas' picture windows to give low thermal conductivity values, which with performance glazing can be as low as $U_w 1.7$

Fixed windows are available in multiple performance options where each option performs at a high level of energy efficiency for hot, mixed and cold climates.

Panoramic windows can be manufactured up to $6m^2$ to frame beautiful views with less divisions than alternate products. This system has been tested up to BAL40 compliance and therefore no further sizing or screening restrictions apply to fixed panels to adhere to these standards.



Performance

- N6 rated (AS2047)
- U-Value as low as 1.7
- No air leakage
- BAL40 tested and certified

Dimensions

Maximum height/width: 4600mm
Maximum sqm: $6m^2$

AliClad FRAME

Our industry leading AliClad frame is designed, created and tested using the best materials and latest technologies. It ensures the highest levels of performance without sacrificing aesthetic appeal.

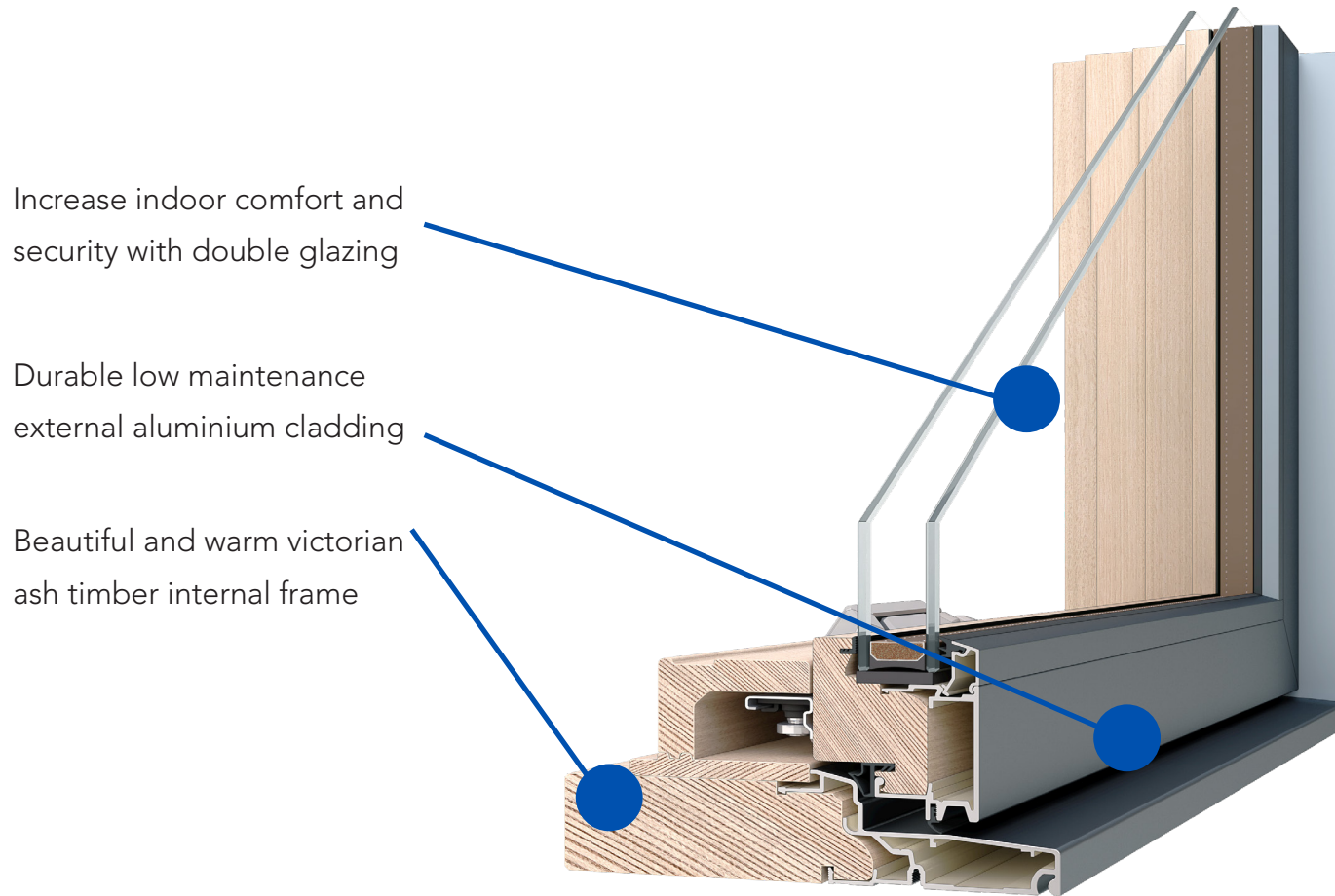

WINDOW OPTIONS

Miglas use the highest quality window hardware available, with stainless steel as standard. Interlock stainless steel dual arm operators provide smooth, easy operation with torque matched sizing. Compared to traditional chain winders, these provide a significantly different feel due to ease of use.

Miglas windows are not keyed to avoid deadlocking in emergency or fire escape situations, however they still provide greater security against forced entry with multiple locking points.

CONTRIBUTION TO THE THERMAL PERFORMANCE

The sash locks contribute to the positive closure of the window. The additional pressure on the gasket supports the airtight sealing of the window resulting in 0.07 A1 rating.

LONG LIFE EXPECTANCY

Miglas use high-quality Interlock hardware. The warranty and expertise of this market leader provide Miglas with the opportunity to supply long lasting, smooth operating hardware.

HARDWARE COLOURS

Window hardware can be selected to match the interior decor of each room, independent of the external facade providing complete design flexibility. As standard, Miglas offer the operator and sash locks in 3 standard colours - silver, white and black.



FLYSCREENS

Flyscreens are supplied as standard to all operable windows, these screens are framed in a powder-coated aluminium profile which traditionally is selected in a colour to closely match that of the window hardware. Screen mesh is available in fibreglass as standard or can be upgraded to aluminium or stainless steel mesh based on project requirements. In some bushfire applications, flyscreens are automatically upgraded to aluminium or stainless mesh as required to meet the relevant standard. The standard screen in fibreglass is very dent-resistant and easiest to ensure taut over a length, however it is more susceptible to damage from wear and tear. Aluminium provides the best visibility, whilst also providing further durability which will not tear but may dent from impact. Stainless steel is the most durable option improving resistance to damage with the tradeoff being a decline in visibility.

AUTOMATION

Window automation for more convenient living.

- Do you want your windows to open effortlessly?
- Do you have inaccessible or hard to reach windows?
- Would you like to have a fully automated home?

For installation and further information about Building Management Systems that can make your project a fully automated home combined with alarm etc. - contact the Miglas Team.

Our range of winders and automation options will help you to meet your desired design requirements. The German engineered and manufactured high-quality range is state-of-the-art.

Contribution to Performance

The electric winders pull the sash into the frame with 200N of tractive force and create an airtight seal with positive pressure on the gaskets.

Long Life Expectancy

German engineered and manufactured to comply with the highest European and Australian standards. The strong stainless steel chain ensures trouble-free operation even in coastal and tropical conditions. All automated winders pass a minimum of 10,000 cycle tests.

Operational Freedom

No manual winding and no climbing to inaccessible areas required. Simple comfort with the flick of a switch. Typical installation requires a momentary 3-position switch (customer supplied) and as an option, Miglas automation can be fitted with rain, wind or smoke detectors for security and comfort. As part of a building automation system, windows cater for the highest requirements for modern commercial and residential applications.

DOORS

As part of your building structure, doors play a vital role in many aspects. Miglas High Performance doors offer exceptional security with a state-of-the-art German multipoint locking system that is near impenetrable. This state-of-the-art locking provides compression on the gaskets tracking the entire frame, minimising air leakage. When teamed with the insulative double glazing technology, it creates an energy-efficient solution that standard doors cannot compete with.

HINGED DOORS

SLIDING DOORS

FRENCH DOORS

CENTER HINGED DOORS

BIFOLD DOORS

ENTRY DOORS

HINGED DOORS

Hinged doors are vital for key access to the home and are available in an inward or outward swinging configuration to suit each application.

All Miglas hinged doors utilise as standard a multipoint lock which provides the highest level of security for your property.

Outward swinging doors utilise concealed hinges as standard, whereas some internal swinging doors may require the use of a more traditional barrel hinge - this is due to opening geometry and clearance of architraves. Miglas hinges are 3D adjustable to ensure optimal clearances which are required for the multipoint locking system.

Hardware

- Concealed 3D adjustable hinges
- Stainless steel handles
- Stainless steel multipoint lock
- Bespoke durable silicone seals

Dimensions

Maximum height: 2700mm
Maximum width: 1100mm

Performance

- N6 rated window & water penetration
- BAL 40 bushfire certified



SLIDING DOORS

A sliding door configuration has the opening leaf sliding in a horizontal direction passing another fixed half. Optionally, these may have four panels in a french configuration with the middle two sliding out to each side to allow for a larger opening.

The sliding door is designed to open the space to a terrace or backyard. Combined with a fixed panorama window, sliding doors provide a perfect combination for any living area.

The specialty designed gaskets (seals) ensure airtight closure and tandem rollers support smooth operation for easy opening and closing.

A multipoint locking system is utilised to further enhance its security and has three individually adjustable locking points with opposing upper and lower lock points. This prevents the door from being lifted off its tracks, providing optimum security which has been tested to withstand over 4kN of forced entry pressure.

Sliding doors have an internal soft-closing sliding timber flyscreen. For easy fitting and replacement, the flyscreen rolls on an aluminium track.



Hardware

- Heavy duty adjustable rollers
- Stainless steel handles
- Multipoint locking system
- Anti-lift guides for security
- Built in timber flydoor
- N4 rated window & water penetration
- BAL 40 bushfire tested & compliant

Dimensions

- Single Configuration:
Maximum height: 2700mm
Maximum width: 3000mm
- French Configuration
Maximum height: 2700mm
Maximum width: 6000mm

FRENCH DOORS

French doors have two opening leaves; a primary and a secondary which open to the outside (optional: inward opening).

French doors are designed to open the space to any external entertaining area, allowing you the choice to open one leaf or two at a time. High-quality German engineered and manufactured multipoint locks and hinges provide smooth handling.

In combination with high-quality gaskets for minimal air-infiltration, French doors provide optimum thermal efficiency.

Concealed 3D adjustable hinges are now standard on all open-out door systems.

This latest technology is the optimal solution to create clear lines for the building facade.



Hardware

- Concealed 3D adjustable hinges
- Stainless steel handles
- Stainless steel multipoint lock
- Bespoke durable silicone seals

Performance

- Up to N5 rated window & water penetration
- BAL 40 bushfire certified

Dimensions

Maximum height: 2700mm
Maximum width: 1000mm per leaf

CENTRE HINGED DOORS

Centre hinged doors have one fixed door and an opening leaf which is hinged in the middle. The opening leaf folds back a full 180 degrees and is a cost-effective alternative to a French door, or Sliding door system whilst still meeting the highest demands of energy efficiency.

Centre hinged doors have an internal sliding flyscreen door with an aluminium insert and spline for easy fitting and replacement of the screen. High-quality German engineered and manufactured multipoint locks and hinges deliver smooth handling.

The multipoint lock provides a high level of security with German concealed 3D adjustable hinges included as standard.

Hardware

- Concealed 3D adjustable hinges
- Stainless steel handles
- Stainless steel multipoint lock
- Bespoke durable silicone seals

Dimensions

Operating Door

Maximum height: 2700mm
Maximum width: 1100mm

Performance

- N5 rated window & water penetration
- BAL 40 bushfire certified

Fixed Door

Maximum height: 2700mm
Maximum width: 3500mm



BIFOLD DOORS

Bifold doors consist of three or more panels and are hinged at one side allowing them to fold into one area for large uninterrupted views.

These multi-leaf AliClad double glazed doors feature specialised Miglas developed hardware. Concealed locks and hinges result in a clean, uncluttered appearance and provide weather performance results far in excess of other Bifold products.

Wide openings are available with the multi-leaf design and combinations of up to eight leaves are possible to create a smooth transition from living areas to a terrace, balcony or garden.

Hardware

- Concealed 3D adjustable hinges
- Concealed shootbolt system
- Bespoke durable silicone seals
- Stainless steel handles
- Stainless steel hangar system
- Multipoint stainless steel locks

Performance

- N5 rated window & water penetration
- BAL 40 bushfire certified

Dimensions

Maximum height: 2700mm
Maximum width: 6000mm



ENTRY DOORS

It is the individual statement of an entry door that makes it such an important aspect of a project. Miglas only offer a small range of entry door solutions in-house but are able to work with external specialists to ensure we fulfil any entry design requirement.

Please contact us for further information on fitting your individual choice into the Miglas system to match fittings, locks and known security/sealing properties as the rest of the doors in your project.

Hardware

- Stainless steel handles
 - Bespoke silicone seals
 - Multipoint locking system
 - Stainless steel adjustable hinges
- OR Concealed 3D adjustable hinges

Dimensions

Maximum height: 2700mm
Maximum width: 1100mm

Performance

- Up to N6 rated window & water penetration.
- BAL 40 bushfire certified



DOOR OPTIONS

Unique door hardware is what sets a Miglas door apart from others. The Miglas system, as standard, utilises high security stainless steel multipoint locks, 15 pin multi-axis anti-pick locking cylinders, concealed 3D adjustable hinges or stainless steel adjustable barrel hinges.

DOOR HANDLES

Every Miglas door is fitted with a Franz Schneider Brakel stainless steel handle as standard. Miglas use the 1076 design with a square escutcheon backplate on hinged doors, whilst the sliding door product has a kinked handle to suit sliding motion. Satin stainless steel is the default finish, however, this can be upgraded to a PVD black coating imbedded into the stainless handles at an additional charge. Additional styles and finishes can be assessed on a project basis but may be subject to surcharges and delivery time delays.

Note; BiFold and French Doors can not have the PVD black option.





MULTIPOINT LOCKS

As standard, each Miglas door uses a stainless steel high-security multipoint locking systems. This allows the door to lock in multiple positions making them near impenetrable to forced entry. The high-tensile handed hooks have a 4.5mm taper which ensures the door is pulled in tight against the seals providing minimal air infiltration and air leakage. Sliding door products use a specialised alignment pin at the locking point to provide a similar pull in against seals. Hinged doors use 3-4 locking points (height dependent), whereas sliding doors use twin opposing hooks and anti-lift blocks for additional security.



CONCEALED HINGES

As standard, Miglas use concealed hinges on all open-out doors, bifold intermediary leaves and some inward opening doors. Concealed hinges allow for a clean uninterrupted look, do not interfere with seal continuity and aid security by inhibiting external tampering. All Miglas hinges provide full 3D adjustment which is vital for a multipoint locking system to ensure the required tolerances for locking can be achieved in the event of building movement.

LOCK CYLINDERS

The locking cylinder is the first deterrent against most break-in attempts. AGB cylinders have been provided with the best technology to guarantee high-security features to protect your home, with 15 multi-axis pins that provide high lock picking resistance in addition to 3 hardened steel anti-drill pins. All AGB cylinders are certified for anti-bumping resistance to ICIM 70R009.

Emergency egress is always vital and as standard Miglas supply a key-knob cylinder configuration for easy escape in the event of an emergency. Miglas strongly advise against deadlocking, and having a secure lock system at all points of the house negates the requirement for deadlocking without compromising on occupants safety.

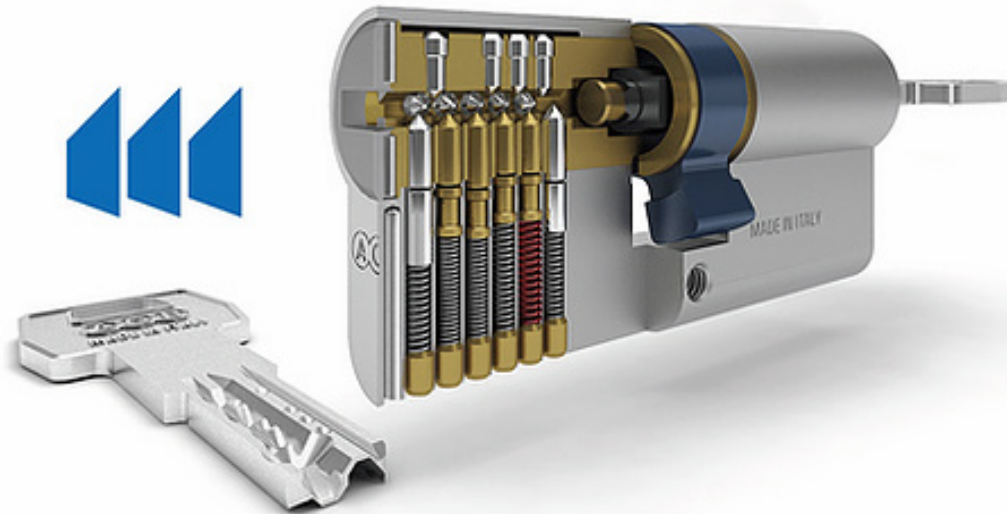



miglas

Miglas Windows is a family owned and operated business that was founded in 1968, by Wally Miglas and has spanned for over three generations. At inception, the company only produced timber single glazed windows and serviced mainly new home builder clients.

A passion to embrace energy efficiency led Miglas to establish a separate enterprise in 1986 within their business in Montrose to focus solely on developing energy-efficient and high-performance windows. Miglas were one of the first to introduce the Australian market to the benefits of double glazing and produced their own high-quality units in house. This side of the business rapidly took off and in 1994 Miglas were the first to capture the advantages of combining timber and aluminium framing into one system.

Nearly 30 years later, this product has established Miglas as industry leaders and today Miglas products continue to evolve and maintain market leadership. The “Miglas Difference” is ever-present as is their ability to rise to any architectural challenge demanded by project requirements.

No matter the project, the Miglas AliClad system perfectly compliments any build.





Start building your dream today

Stay up-to-date with the latest information and product news

visit our website - www.miglas.com.au

Call Us

1300 644 527

Visit our showroom

57-59 Canterbury Road, Montrose VIC

Explore our website

www.miglas.com.au

* This brochure features an extensive range of Miglas products that are generally available at the time of print. Miglas' passion for constant innovation and improvement means that designs, dimensions and options may alter without notice.